

# Service Manual

Semi-Automatic Turntable System

SL-B200

SL-B200(K)

[E], [EK], [XL], [EG], [EB],  
[EF], [Ei], [EC], [XA], [XM]

原本のため  
[EH]

持出厳禁  
Areas

\* [XL] is available in Switzerland and Scandinavia.

\* [XL] is available in United Kingdom.

\* [XL] is available in Australia.

\* [EG] is available in F.R. Germany.

\* [EB] is available in Belgium.

\* [EH] is available in Holland.

\* [EF] is available in France.

\* [Ei] is available in Italy.

\* [EC] is available in Czechoslovakia.

\* [XA] is available in Southeast Asia, Oceania, Africa,  
Middle Near East and Central South America.

\* [XM] is available in Central South America.

- \* The colors of this model include silver and black.
- \* The black type model is provided with (K) in the Service Manual.

**TAP** is the standard mark for plug-in-connector type. Products carrying this mark are interchangeable and adaptable among each other.

English

## Specifications

Specifications are subject to change without notice for further improvement.  
Weight and dimensions shown are approximate.

### ■ General

<b>Power supply:</b>	220V, AC 50/60 Hz (For Continental Europe)
<b>Power consumption:</b>	3 W
<b>Dimensions:</b> (W×H×D)	43 × 9.3 × 37.5 cm (16-15/16" × 3-21/32" × 14-3/4") Maximum height when top (dust cover) is open. 43 × 36 × 41 cm (16-15/16" × 14-5/32" × 16-1/8")
<b>Weight:</b>	3.3 kg (7.3 lb.)

### ■ Turntable section

<b>Type:</b>	Semi-automatic turntable Auto return Auto stop
<b>Drive method:</b>	Belt drive
<b>Motor:</b>	DC motor
<b>Drive control method:</b>	Frequency generator servo control
<b>Turntable platter:</b>	Aluminum die-cast Diameter 30.4 cm (12 inches)
<b>Turntable speeds:</b>	33-1/3 rpm and 45 rpm
<b>Wow and flutter:</b>	0.045% WRMS (JIS C5521) ±0.06% peak (IEC 98A Weighted)
<b>Rumble:</b>	-70 dB (IEC 98A Weighted)

### ■ Tonearm section

<b>Type:</b>	Statically-balanced straight tonearm Plug-in connector cartridge system
--------------	--

<b>Effective length:</b>	230 mm (9-1/16")
<b>Overhang:</b>	15 mm (19/32")
<b>Tracking error angle:</b>	Within 2°32' at the outer groove of 30 cm (12") record Within 0°32' at the inner groove of 30 cm (12") record
<b>Effective mass:</b>	13.5 g (including cartridge)
<b>Stylus pressure:</b>	1.25 g
<b>Applicable cartridge weight:</b>	6 g

### ■ Cartridge section

<b>Type:</b>	Moving magnet stereo cartridge
<b>Magnet circuit:</b>	All laminated core
<b>Frequency response:</b>	10 Hz~35 kHz 20 Hz~10 kHz ±1 dB
<b>Output voltage:</b>	2.5 mV at 1 kHz, 5 cm/s. zero to peak lateral velocity (7 mV at 1 kHz, 10 cm/s. zero to peak 45° velocity [DIN 45 500])
<b>Channel separation:</b>	22 dB at 1 kHz
<b>Channel balance:</b>	Within 2 dB at 1 kHz
<b>Recommended load impedance:</b>	47 kΩ~100 kΩ
<b>Compliance (dynamic):</b>	12×10 <sup>-6</sup> cm/dyne at 100 Hz
<b>Stylus pressure range:</b>	1.25 ±0.25 g (12.5± 2.5 mN)
<b>Weight:</b>	6 g (cartridge only)
<b>Replacement stylus:</b>	EPS-27CS
<b>Phono cable capacitance:</b>	100 pF

# Technics

Matsushita Electric Trading Co., Ltd.  
P.O. Box 288, Central Osaka Japan

## CONTENTS

	Page		Page
LOCATION OF CONTROLS .....	2	Tonearm Parts .....	6
SAFETY PRECAUTIONS .....	2	SCHEMATIC DIAGRAM .....	7
DISASSEMBLY INSTRUCTIONS .....	3 ~ 5	CIRCUIT BOARD AND	
MEASUREMENTS AND ADJUSTMENTS .....	5, 6	WIRING CONNECTION DIAGRAM .....	8
REPLACEMENT PARTS LIST		EXPLODED VIEWS .....	9, 10
Electrical Parts .....	6	Mechanism Plate .....	11
Cabinet & Chassis Parts .....	6	PACKING .....	12

## LOCATION OF CONTROLS

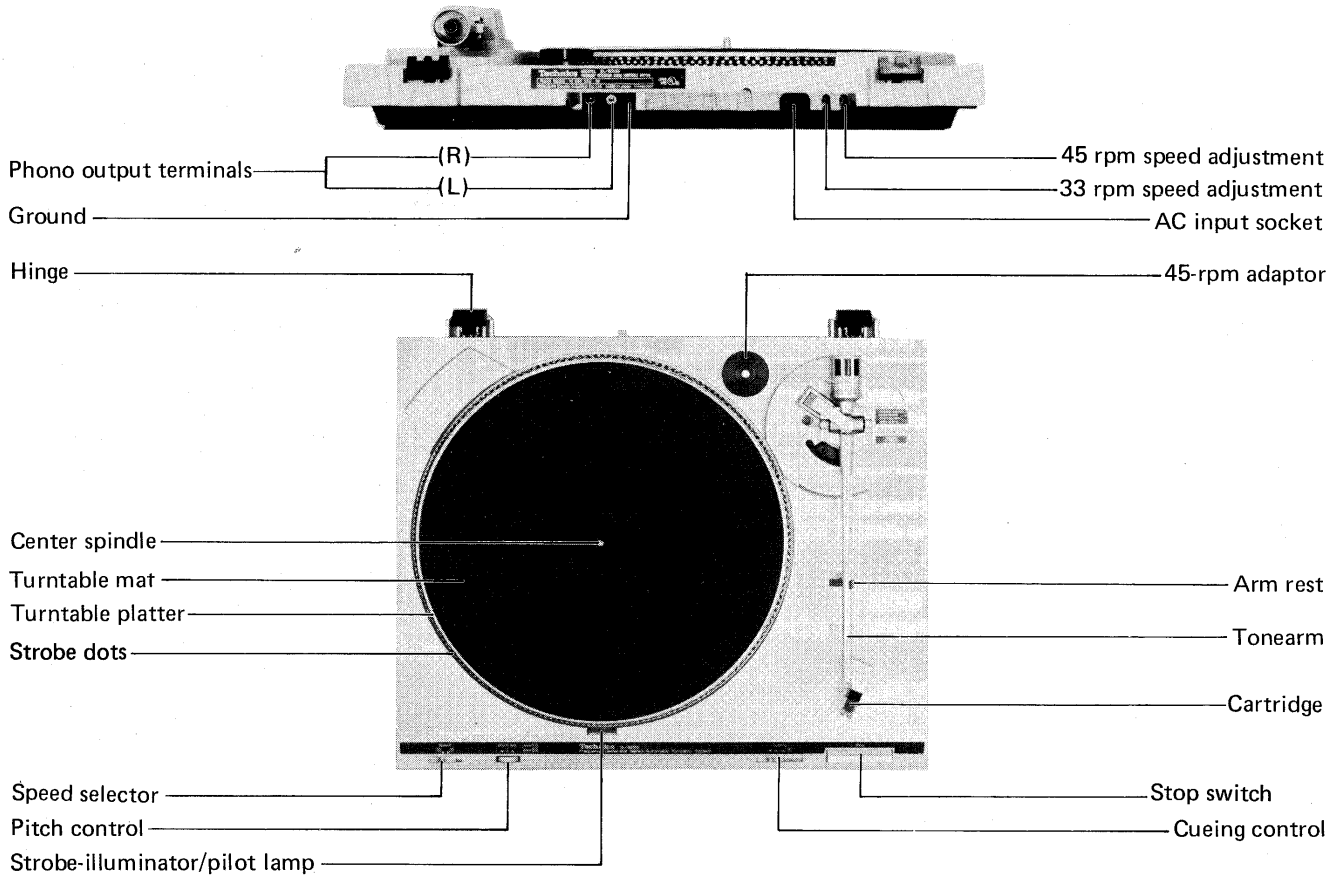

## SAFETY PRECAUTIONS

1. Before servicing, unplug the power cord to prevent an electric shock.
2. When replacing parts, use only manufacturer's recommended components for safety.
3. Check the condition of the power cord. Replace if wear or damage is evident.
4. After servicing, be sure to restore the lead dress, insulation barriers, insulation papers, shields, etc.
5. Before returning the serviced equipment to the customer, be sure to make the following insulation resistance test to prevent the customer from being exposed to a shock hazard.

### INSULATION RESISTANCE TEST

1. Unplug the power cord and short the two prongs of the plug with a jumper wire.
2. Turn on the power switch.
3. Measure the resistance value with ohmmeter between the jumpered AC plug and each exposed metal cabinet part, such as screwheads antenna, control shafts, handle brackets, etc. Equipment with antenna terminals should read between  $3M\Omega$  and  $5.2M\Omega$  to all exposed parts. (Fig. 1-1) Equipment without antenna terminals should read approximately infinity to all exposed parts. (Fig. 1-2)

**Note:** Some exposed parts may be isolated from the chassis by design. These will read infinity.

4. If the measurement is outside the specified limits, there is a possibility of a shock hazard. The equipment should be repaired and rechecked before it is returned to the customer.

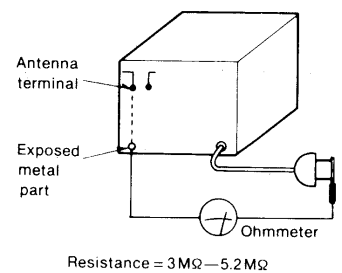

(Fig. 1-1)

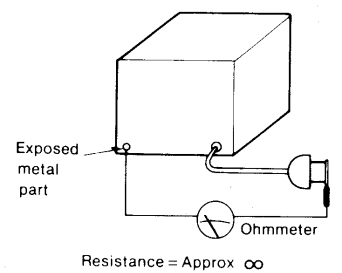

(Fig. 1-2)

**DISASSEMBLY INSTRUCTIONS**

● **How to remove the cartridge (Fig. 2)**

1. Fix the tonearm on the arm rest.
2. Remove the cartridge setscrew ①.
3. Pull out the cartridge with care not to let the hand touch the stylus tip.
4. When setting the cartridge, match the cartridge pin with the tonearm connector, and completely insert the cartridge and tighten the setscrew.

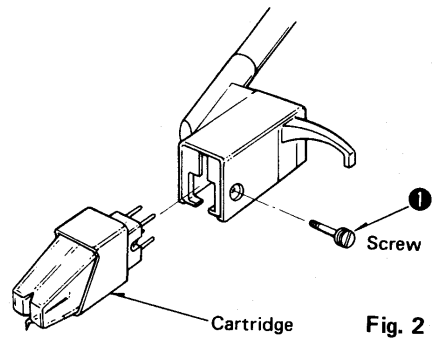

● **How to remove the stylus (Fig. 3)**

1. Pull out the stylus with care not to touch the stylus tip.
2. When setting the stylus, match the stylus sleeve with the fitting hole in the cartridge body, and completely insert the stylus and make sure that there is no gap between the stylus knob and main body.

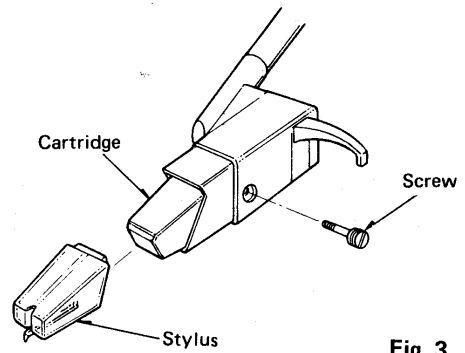

● **How to remove the bottom board (Fig. 4)**

1. Fix the tonearm on the arm rest.
2. Remove the turntable mat, belt and turntable platter.
3. Close the dust cover, and turn over the unit with care.
4. Remove the 5 setscrews [ Fig. 4: ② ~ ⑥ ] of the bottom board.

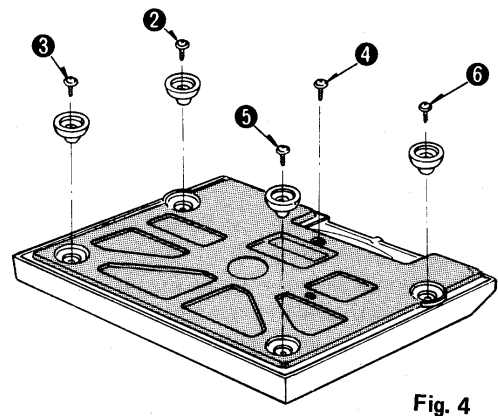

● **How to remove the drive circuit P.C.B. (transformer) and motor**

1. Remove the bottom board. (Refer to "How to remove the bottom board".)
2. Remove the 3 setscrews [ Fig. 5 (A) : ⑦ ~ ⑨ ] of the P.C.B., then the drive circuit P.C.B. (transformer) and AC socket can be removed.
3. To remove the transformer from the drive circuit P.C.B., unsolder the 5 transformer terminals and release the claw to remove the transformer from the P.C.B.
4. To remove the motor, remove the 3 setscrews [ Fig. 5 (B) : ⑩ ~ ⑫ ] which secure the main body and motor, and then pull out the connector (CN105) in the P.C.B.

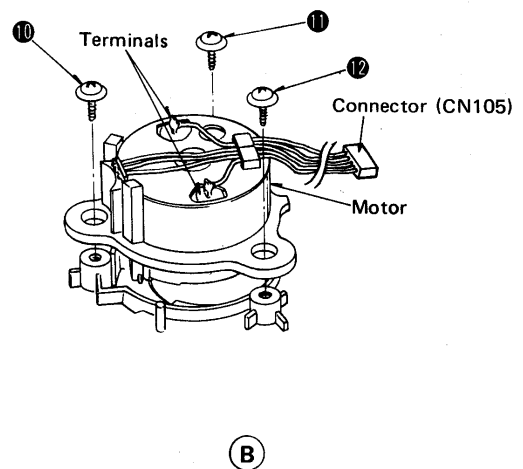
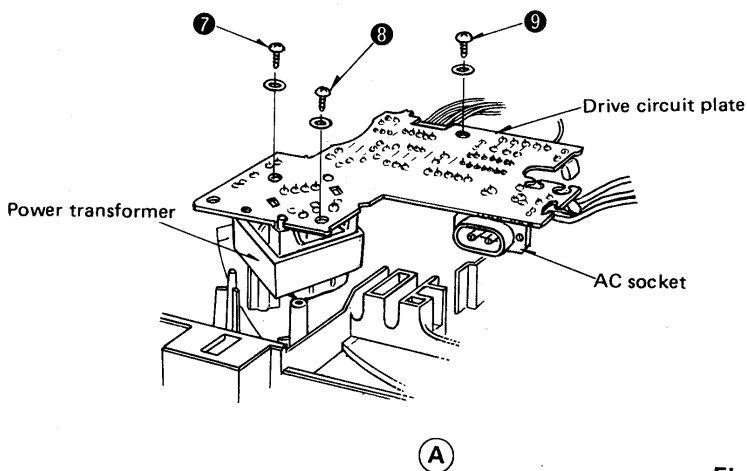

Fig. 5

● **How to remove the mechanical plate (Fig. 6)**

1. Remove the bottom board. (Refer to "How to remove the bottom board".)
2. Remove the 5 setscrews [ Fig. 6: ⑬ ~ ⑰ ] of the mechanical plate and output terminal shielding plate, and the setscrew ⑱ of the Ground terminal.
3. When fitting the mechanical plate, do the following beforehand.
  - (1) Turn the turntable shaft to rotate the main gear until it comes to the no-gear part. (Fig. 7)
  - (2) Shift the cueing lever of the mechanical plate to the "cueing up" position. (Fig. 8)

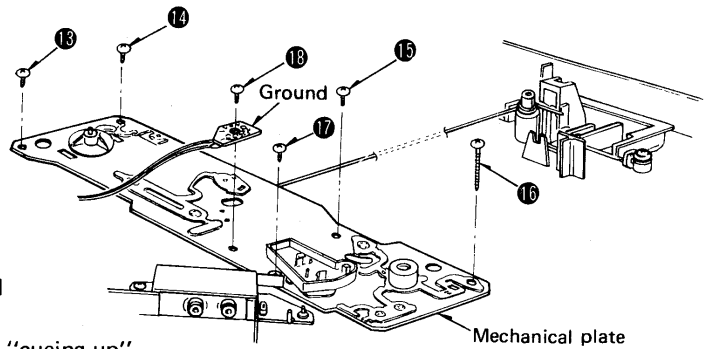

Fig. 6

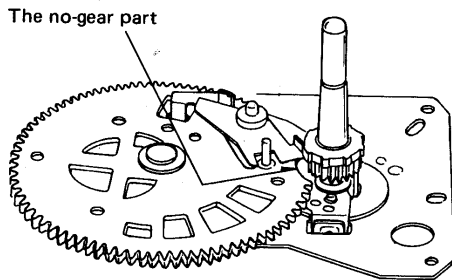

Fig. 7

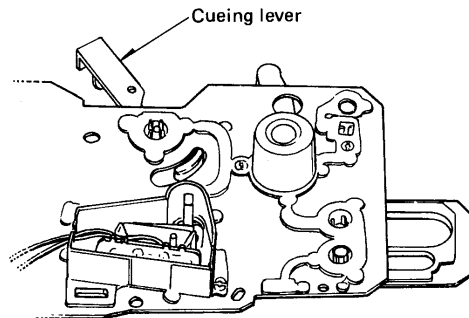

Fig. 8

● **How to remove the Pu fixing plate (Fig. 9)**

1. Remove the bottom board. (Refer to "How to remove the bottom board".)
2. Remove the mechanical plate. (Refer to "How to remove the mechanical plate".)
3. Remove the setscrew ⑲ of the Pu fixing plate.

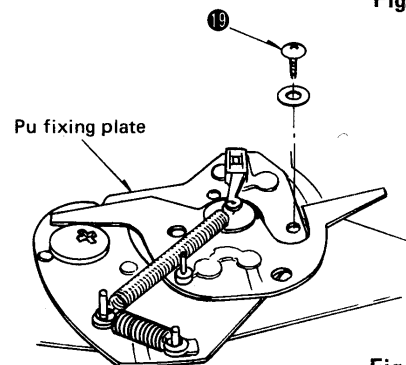

Fig. 9

● **How to remove the tonearm (Fig. 10)**

1. Remove the Pu fixing plate. (Refer to "How to remove the Pu fixing plate".)
2. Unsolder the 5 Pu leads of output terminal.
3. Remove the 2 setscrews [ Fig. 10: ⑳ ~ ㉑ ] of the lift plate.

Pu lead wiring method

White	L CH (+) terminal
Blue	L CH (-) terminal
Red	R CH (+) terminal
Green	R CH (-) terminal
Black	Ground terminal

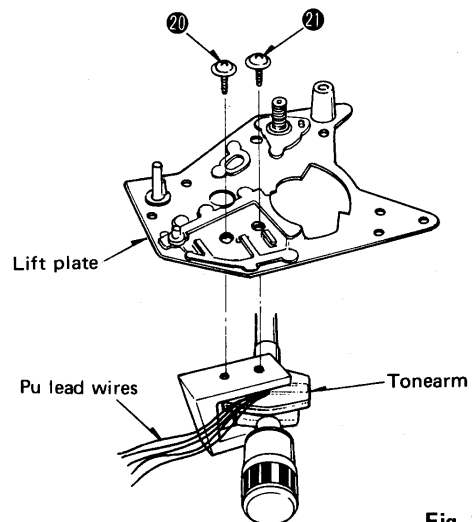

Fig. 10

● **How to remove the lift plate (Fig. 11)**

1. Remove the Pu fixing plate. (Refer to "How to remove the Pu fixing plate".)
2. Remove the 3 setscrews [ Fig. 11: 22 ~ 24 ] of the lift plate.

● **How to remove the arm lift**

1. Remove the Pu fixing plate. (Refer to "How to remove the Pu fixing plate".)
2. Remove the lift plate (Refer to "How to remove the lift plate".)
3. Remove the setscrew [ Fig. 12: 25 ] of the arm lift cover.
4. Remove the washer [ Fig. 12: 26 ] from the arm lift rod.
5. Pull out the arm lift rod in the direction of the arrow.

**Caution:**

★ Be sure to adjust the arm lift height. (Refer to page 5 Fig. 13.)

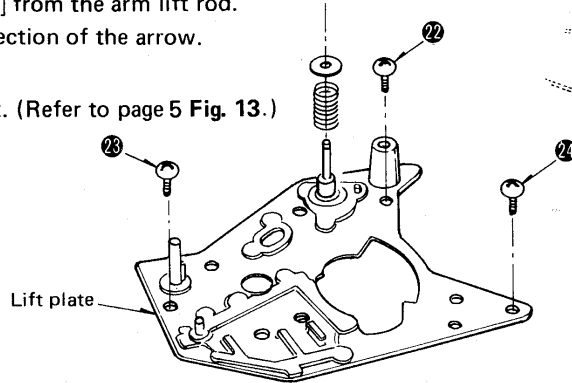

Fig. 11

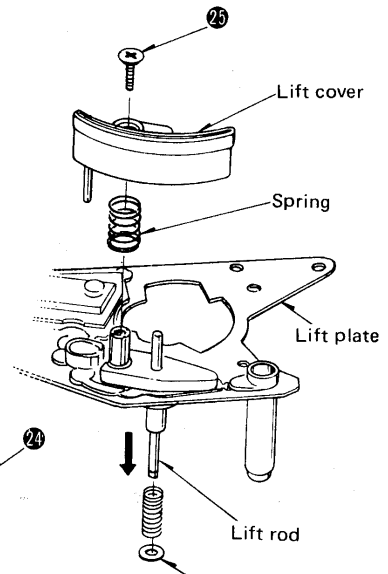

Fig. 12

■ **MEASUREMENTS AND ADJUSTMENT**

● **Arm-lift height adjustment**

The arm-lift height (distance between the stylus tip and the record surface when the cueing control is at the "▼" position) has been adjusted at the factory to approximately 4 to 6 mm (5/32" ~ 1/4"). (Fig. 13)

If the clearance is too narrow or too wide, turn the adjustment screw clockwise or counterclockwise. (Fig. 14)

**Clockwise rotation**

—distance between the record and stylus tip is decreased.

**Counterclockwise rotation**

—distance between the record and stylus tip is increased.

● **Adjustment of automatic return position (Fig. 15)**

(Remove the rubber cap.)

1. Put the stylus protector on the cartridge.
2. Move the tonearm toward the center of the record.

The auto-return adjustment screw will appear.

If the tonearm tends to return to the arm rest before the play has finished.

—turn counterclockwise.

If the tonearm fails to return after the final groove.

—turn clockwise.

● **Adjustment of rotational speed**

1. Set the speed selector switch to the "45" position.
2. Turn the VR102 with a screw driver from the back of the set to the rated rotation (45 rpm) and check the rotation with a strobe while adjusting the speed. (Fig. 16)
3. Set the speed selector switch to the "33" position.
4. Turn the VR101 with a screwdriver from the back of the set to the rated rotation (33-1/3 rpm) and check the rotation with a strobe while adjusting the speed. (Fig. 16)

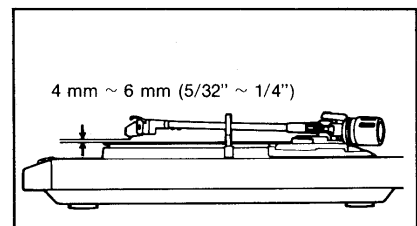

Fig. 13

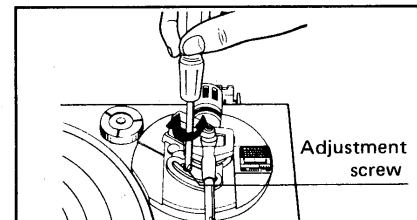

Fig. 14

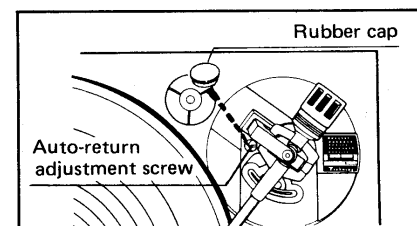

Fig. 15

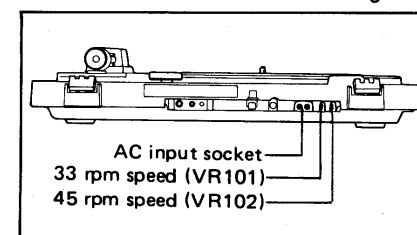

Fig. 16

## ● Speed adjustment (pitch control) (Fig. 17)

There are strobe-lines cut on this turntable platter to indicate correct rotational speed.

If the strobe-line appears to be moving as the turntable rotates, adjust while playing a record.

1. Set the speed selector to the speed to be adjusted.
2. Watch the dot pattern on the side of the platter. Turn the pitch control one way or the other until the dots appear to stand still. This is the correct speed.
3. Turning the pitch control in the "+" direction increases the speed.
4. Turning the pitch control in the "-" direction decreases the speed.

### Note:

#### Strobe dot pattern

This unit's strobe illuminator operates at the AC line frequency which generally has a 0.2% fluctuation.

This fluctuation, when present, may make the strobe pattern appear to change. However, actual turntable speed does not change, because the DC motor is not affected by AC power line frequency.

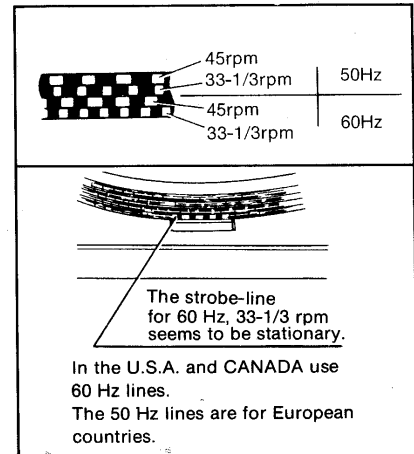

Fig. 17

## REPLACEMENT PARTS LIST

- Notes:
1. Part numbers are indicated on most mechanical parts. Please use this part number for parts orders.
  2. Important safety notice:  
Components identified by  $\Delta$  mark have special characteristics important for safety.  
When replacing any of these components, use only manufacturer's specified parts.
  3. Bracketed indications in Ref. No. columns specify the area. Parts without these indications can be used for all areas.
  4. The "S" mark is service standard parts and may differ from production parts.
  5.  $\text{\textcircled{K}}$ -marked parts are used for black only, while  $\text{\textcircled{O}}$ -marked parts are for silver type only.
  6. Parts other than  $\text{\textcircled{K}}$  and  $\text{\textcircled{O}}$ -marked are used for both black and silver types.
  7. The parenthesized number in the column of description stand for the quantity per set.

Black type model No.: SL-B200 (K)

Ref. No.	Part No.	Description	Ref. No.	Part No.	Description	Ref. No.	Part No.	Description
<b>INTERGRATED CIRCUIT</b>			<b>RESISTORS</b>			<b>CABINET and CHASSIS PARTS</b>		
IC101	SVIBA6301	FG Servo	R111	S ERD25TJ183	18K $\Omega$	11 (XA) (XM)	SFNNB62X01	Name Plate (1)
<b>TRANSISTOR</b>			R112	S ERD25TJ824	820K $\Omega$	11 (Other)	SFNNB62R01	Name Plate (1)
Q1	2SD638	Regulator	R113 (Except XA, XM)	S ERD25FJ102	1K $\Omega$	(Areas)		
Q101	2SD1189	Switching	R114	S ERG1ANJ180	18 $\Omega$	12	SFDJZ15R01	Socket, Phono (1)
<b>DIODES</b>			R115 (Except XA, XM)	S ERDS1TJ154T	150K $\Omega$	13	SFUZZ15R01	Rod Stop (1)
D1	$\Delta$ SVDS1WB40	Rectifier	R116 (XA, XM only)	S ERD25FJ100	10 $\Omega$	14	SFKTZ15R01	Knob, Stop (1)
D2	MA1082	8.2V Zener	<b>CAPACITORS</b>			15	SFQHZ15R01	Spring, Stop Knob (1)
<b>VARIABLE RESISTORS</b>			C1, 2	S $\Delta$ ECKD1H223PF	0.022 $\mu$ F	16	SFUPZ15R03	Lever, Cueing (1)
VR101, 102	EVN59AA00B24	Speed Adjustment 20K $\Omega$ (B)	C3	ECEA1EU331	330 $\mu$ F	17	SFKTZ15R04	Knob, Cueing (1)
VR103	EVLE5AT12B14	Pitch Control 10K $\Omega$ (B)	C4 (EK) (XL) (E) (EC) $\Delta$	ECQU2A103MF	0.01 $\mu$ F	18	SFQPZ15R02	Click Spring (1)
<b>SWITCHES</b>			C4 (Other) (Areas) $\Delta$	ECQE2A103MZ	0.01 $\mu$ F	18-1	SFYB-5-32	Steel Ball (1)
S1	$\Delta$ SFDSS5GLP	Start/Stop	C5	S ECEA1CS330	33 $\mu$ F	19	SFUPZ15R05	Plate, Cueing (1)
S2 (XA, XM) only $\Delta$	SFDSHW02066	Voltage Selector	C101	ECQM1H103KV	0.01 $\mu$ F	20	SFKTZ15R02	Knob, Speed (1)
S101	SFDSHSW0739	Speed Selector	C102	ECQM1H823JV	0.082 $\mu$ F	21	SFAUZ15R01	Bottom Board (1)
<b>LAMP</b>			C103	ECQM1H473KV	0.047 $\mu$ F	22	SFGAZ15R01	Insulator, Front (2)
NL1	$\Delta$ SFDNE2HU	Strobe	C104, 105	S ECEA50Z1	1 $\mu$ F	23	SFGAZ15R02	Insulator, Rear (2)
<b>FUSE</b>			C107	S ECEA50Z3R3	3.3 $\mu$ F	24	SFKTB62M01	Knob, Pitch (1)
F1 (XA) only $\Delta$	XBAS2C005TIA	50mA 250V	C109	S ECEA1HS100	10 $\mu$ F	25	SFKKB62M01	Ornament, Front (1)
<b>POWER TRANSFORMER</b>			C110, 111	S ECEA25Z4R7	4.7 $\mu$ F	26	SFGZZ15R02	Washer (1)
T1 (EK) (XL) $\Delta$	SLTF6582	Power Source	<b>CABINET and CHASSIS PARTS</b>			<b>TONEARM and ARM BASE</b>		
T1 (XA) (XM) $\Delta$	SLTF6546	Power Source	1	SFADZ15R01	Dust Cover (1)	30	$\text{\textcircled{O}}$ SFPAMZ1501A	Tonearm Ass'y (Silver) (1)
T1 (Other) (Areas) $\Delta$	SLT35K64E	Power Source	2	SFGZZ15R01	Cushion Rubber, Dust Cover (2)	30	$\text{\textcircled{K}}$ SFPAMZ1502A	Tonearm Ass'y (Black) (1)
<b>RESISTORS</b>			3	SFTGZ15R01	Turntable Mat (1)	31	EPC-P27S	※Cartridge (1)
R1, 3	S ERD25FJ221	220 $\Omega$	4	SFTEB62M01	Turntable Platter (1)	32	EPS-27CS	※Stylus (1)
R2	S ERD25FJ181	180 $\Omega$	5	SFGB321-1	Belt (1)	33	SFCNC02301	Cover, Stylus (1)
R104 (XA, XM) $\Delta$	S ERG1ANJ103	10K $\Omega$	6	SFMHBL3N01Z	Motor Ass'y (1)	34	SFKUZ15R01	Arm Rest (1)
R104 (Other) (Areas) $\Delta$	ERG2SJ333	33K $\Omega$	7	SFUMB62M01	Cover, Strobe (1)	35	SFUMZ15R58	Cover, Arm Lift (1)
R105	S ERD25FJ272	2.7K $\Omega$	8	SFACB62M01	Cabinet (Silver) (1)	36	$\text{\textcircled{O}}$ SFGK170-01	Cap, Rubber (Silver) (1)
R106	S ERD25FJ223	22K $\Omega$	8	$\text{\textcircled{K}}$ SFACB62M21	Cabinet (Black) (1)	36	$\text{\textcircled{K}}$ SFGK171F01	Cap, Rubber (Black) (1)
R107, 110	S ERD25FJ152	1.5K $\Omega$	9 (EK) $\Delta$	SFDJHSC0498	AC Socket (1)	37	SFKKZ15R01	Plate, Cancellor (1)
R108	S ERD25FJ472	4.7K $\Omega$	9 (XA) (XM) $\Delta$	SFDJHSC0509	AC Socket (1)	38	SFUPZ15R52A	Arm Base Ass'y (1)
R109	S ERD25FJ682	6.8K $\Omega$	9 (Other) (Areas) $\Delta$	SFDJHSC0505	AC Socket (1)	39	SFUPZ15R51A	Lift Base Ass'y (1)
			10	SFATZ15R01A	Hinge (2)	40	SFQAZ15R51	Spring, Arm Lift (1)
			11 (E) (EC)	SFNNB62S01	Name Plate (1)	41	SFQHZ15R55	Spring (1)
			11 (EK) (XL)	SFNNB62G01	Name Plate (1)			

## SCHEMATIC DIAGRAM

(This schematic diagram may be modified at any time with the development of new technology.)

[For continental Europe]

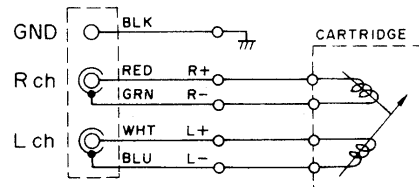
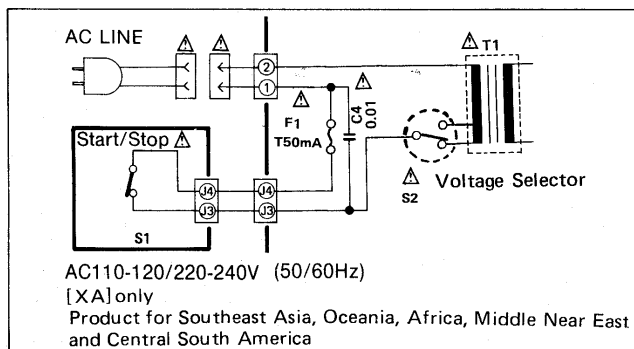
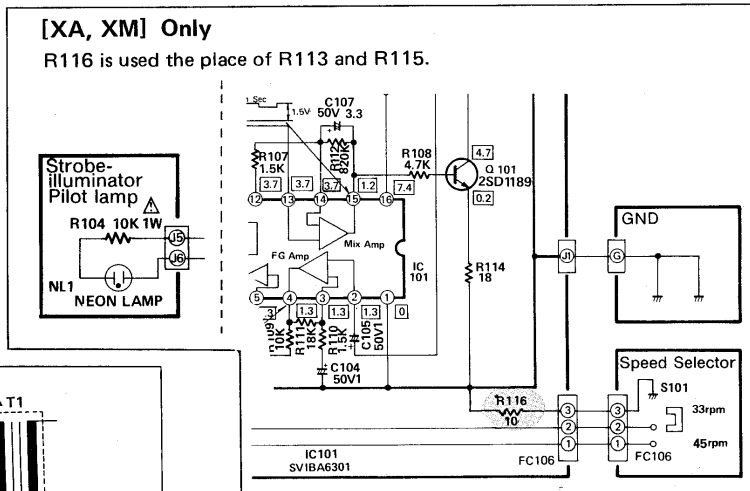
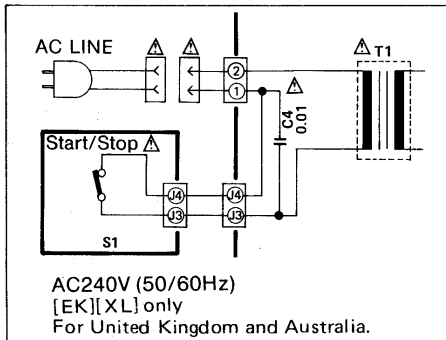
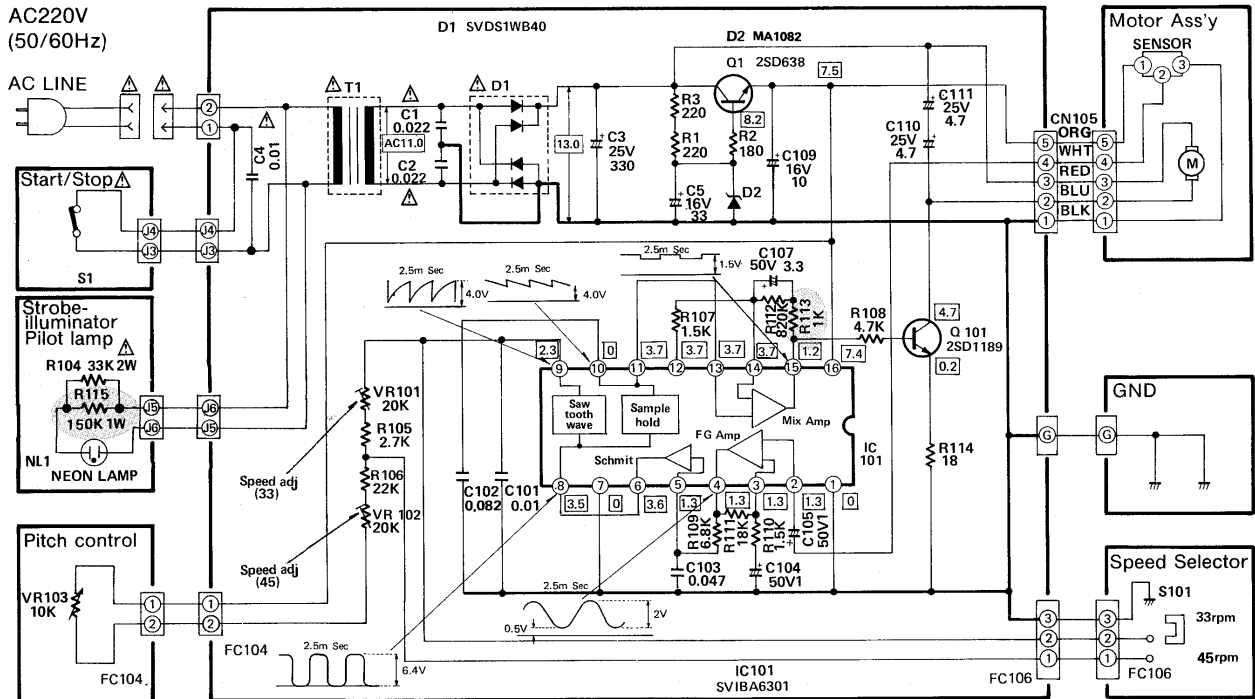

### Notes:

1. S1 : Start/stop switch in "on.. position.
2. S101: Speed selector switch in "33-1/3 rpm" position  
33-1/3 rpm ↔ 45 rpm
3. S2: Voltage selector switch in "AC110-120/220-240V" position
4. The value and waveform in  are of the reference voltage for the turntable rotation (33-1/3 rpm) of this unit, measured by DC voltmeter (high impedance) and oscilloscope on the basis of chassis.

Therefore the measured value may include some error depending on the internal impedance of DC circuit tester and other conditions.

### 5. Important safety notice:

Components identified by  mark have special characteristics important for safety. When replacing any of these components, use only manufacturer's specified parts.

# CIRCUIT BOARD AND WIRING CONNECTION DIAGRAM

Ground (Earth Lines)

[Other Areas]

For Continental Europe

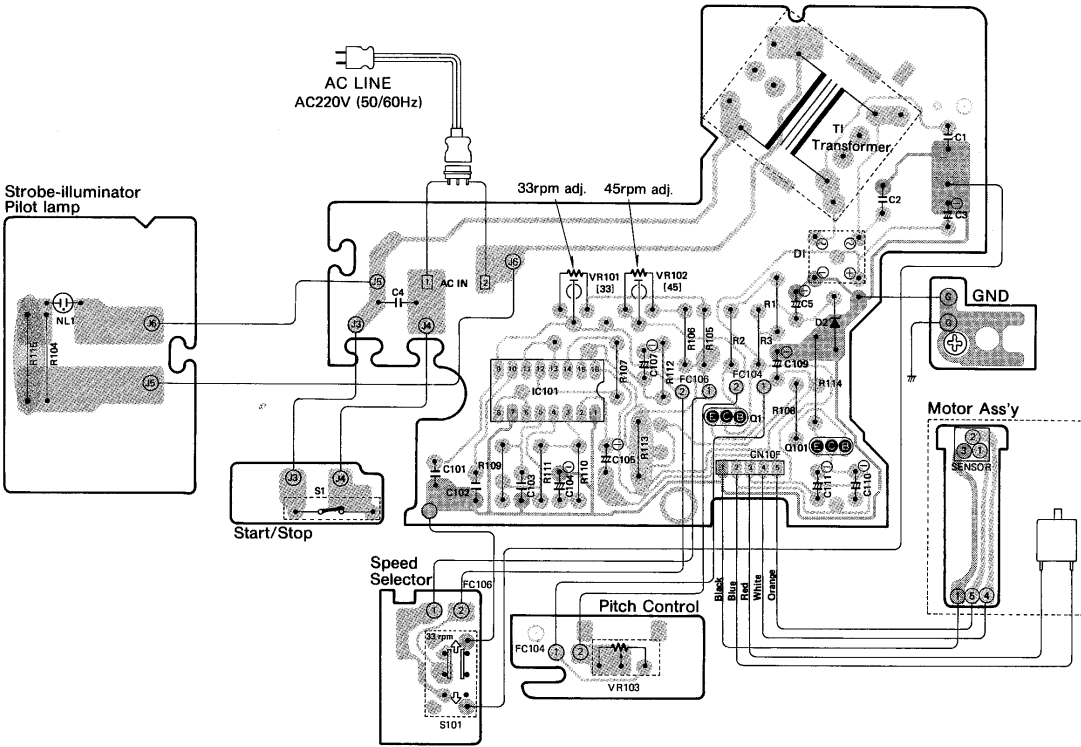

● Terminal guide of IC, transistors and diode

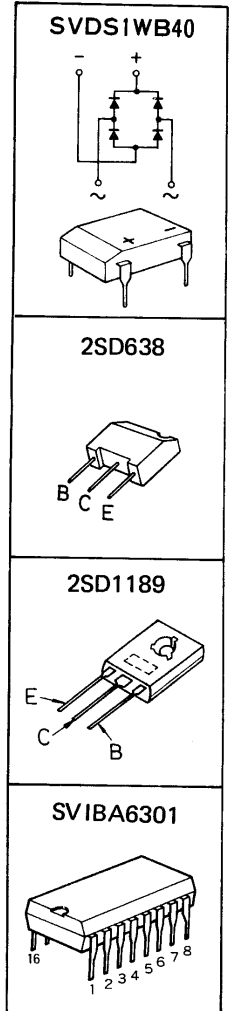

[XA] Only

Product for Southeast Asia, Oceania, Africa, Middle Near East and Central South America.

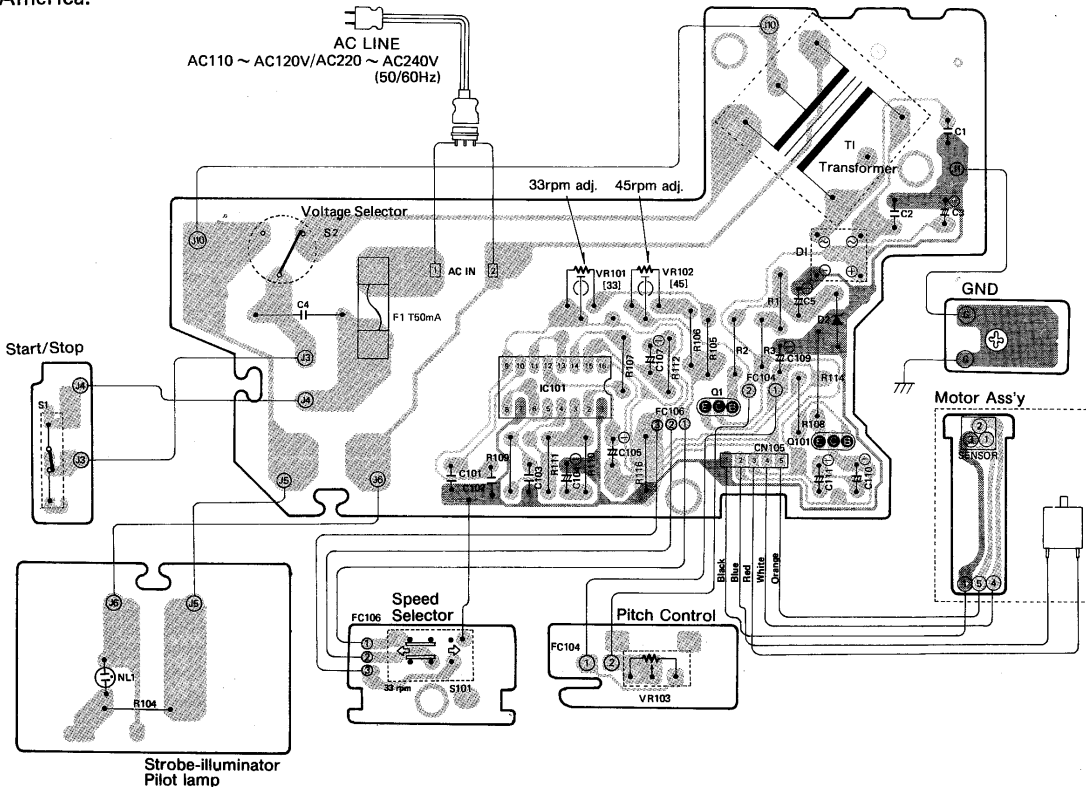



EXPLODED VIEWS

● Cabinet and chassis

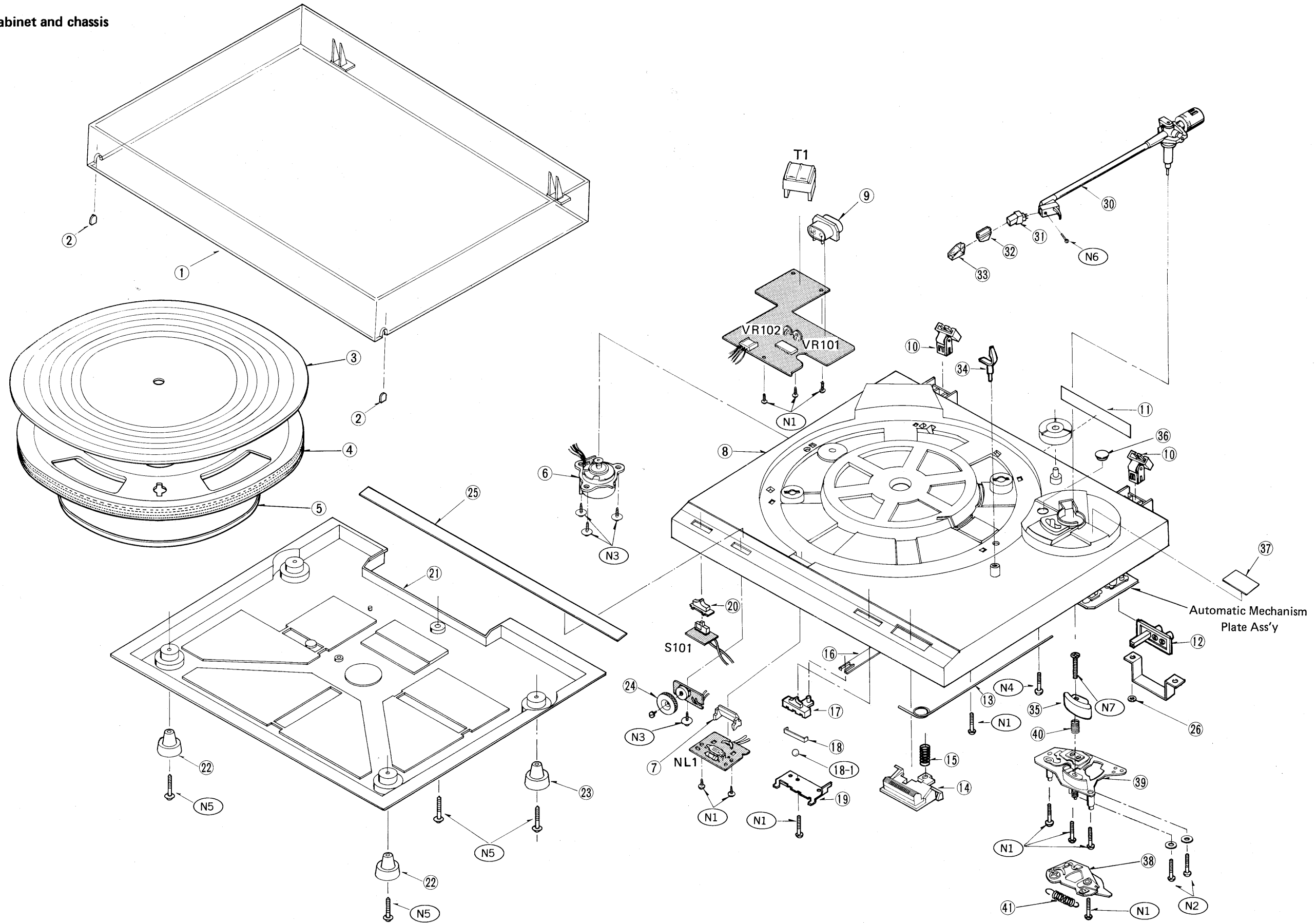

## EXPLODED VIEWS

### Automatic mechanism plate

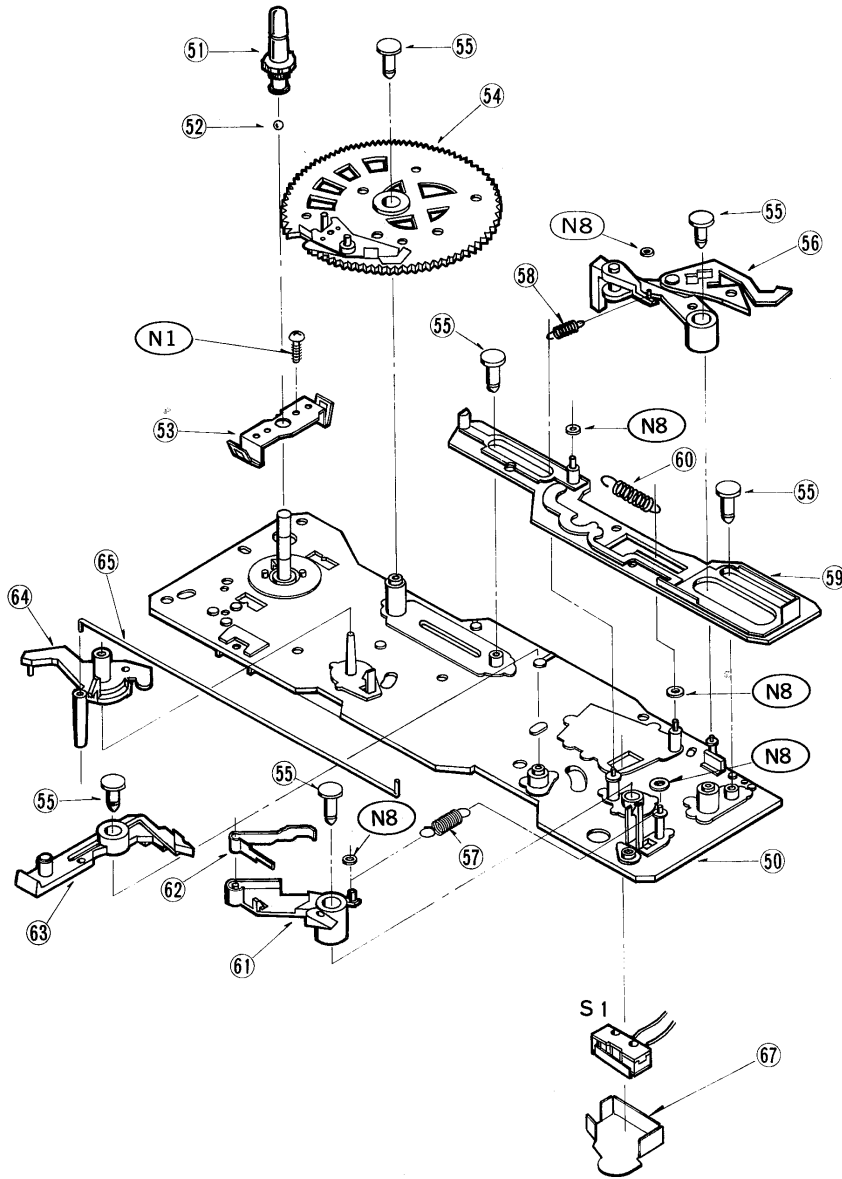

Ref. No.	Part No.	Description	Ref. No.	Part No.	Description	Ref. No.	Part No.	Description	
<b>AUTOMATIC MECHANISM ASS'Y</b>			<b>SCREWS and WASHERS</b>			<b>ACCESSORIES</b>			
50	SFUKZ15R51E	Plate, Automatic Mechanism (1)	N1	S	XTV3+8BFN	A1	(Ei) SFNUB62i01	Instruction Book (1)	
51	SFTUZ15R51E	Turntable Shaft(1)	N2		XTN3+F12	A1	{Other Areas}	SFNUB62S01	Instruction Book (1)
52	SFYB-5-32	Ball (1)	N3		SFXGB33N01	A2	{EK}△	SFDAC05G02	AC Cord (1)
53	SFUPZ15R55	Plate, Ground (1)	N4		XTV3+30J	A2	{XL}△	SFDAC05L01	AC Cord (1)
54	SFUGZ15R51E	Main Gear Ass'y (1)	N5		XTW3+14QFYR	A2	{XA} {XM}△	SFDAC05X01	AC Cord (1)
55	SFUMZ15R56	Pin (6)	N6		SFPEVOP301	A2	{Other Areas} △	SFDAC05E02	AC Cord (1)
56	SFUMZ15R54E	Lever Ass'y (1)	N7		XTS3+16FFZ	A3		SFWE212-01	45r.p.m Adaptor(1)
57	SFQHZ15R53	Spring (1)	N8		SFXWZ15R51	A4	{XL} only	SFDLC05N01	Ground Wire (1)
58	SFQHZ15R52	Spring (1)	<b>ACCESSORIES</b>			A4	{Other Areas}	SFDLZ15R01	Ground Wire (1)
59	SFUBZ15R51	Plate, Drive (1)	A1	{EK}	SFNUB62G01			SFDHC05N01	Phono Cord (1)
60	SFQHZ15R54	Spring (1)	A1	{XL} {XA}	SFNUB62X01			SFDKi19118	2P Plug (1)
61	SFUMZ15R60	Cam, Cueing (1)	A1	{XM}	SFNUB62R01				
62	SFQPZ15R51	Spring Plate (1)	A1	{EG}	SFNUB62F01				
63	SFUMZ15R51	Lever, Cueing (1)	A1	{EF}					
64	SFUMZ15R52	Connector (1)							
65	SFQSZ15R51	Actuating Rod, Actuating (1)							
67	SFUZB62M01	Cover, Switch (1)							

## PACKING

Ref. No.	Part No.	Description
<b>PACKING PARTS</b>		
P1	(EF)○ SFHPPB62C01	Carton Box (Silver) (1)
P1	(EF)Ⓚ SFHPPB62C21	Carton Box (Black) (1)
P1	{Other Areas} ○ SFHPPB62M01	Carton Box (Silver) (1)
P1	{Other Areas} Ⓚ SFHPPB62M21	Carton Box (Black) (1)
P2	SFH336M01	Pad, Front Left (1)
P3	SFH336M02	Pad, Front Right (1)
P4	SFH336M03	Pad, Rear Left (1)

Ref. No.	Part No.	Description
<b>PACKING PARTS</b>		
P5	SFH336M04	Pad, Rear Right (1)
P6	SFHKZ15R01	Clamper, Turntable (2)
P7	SFHZZ15R01	Pad, Weight (1)
P8	SFHZZ15R02	Stopper, AC Cord (1)
P9	SFHZZ15R03	Clamper, Arm (1)
P10	SFHZD03M01	Sheet (1)
P11	SFYH60X60	Polyethylene, Unit /Dust Cover (2)
P12	SFYF30B35	Sheet (1)

Ref. No.	Part No.	Description
<b>PACKING PARTS</b>		
P13	SFYH17X16	AC Cord (1)
P14	SFYF05A06	Polyethylene 45r.p.m Adaptor(1)
P15	SFHZD15R01	Pad, Turntable Mat (1)

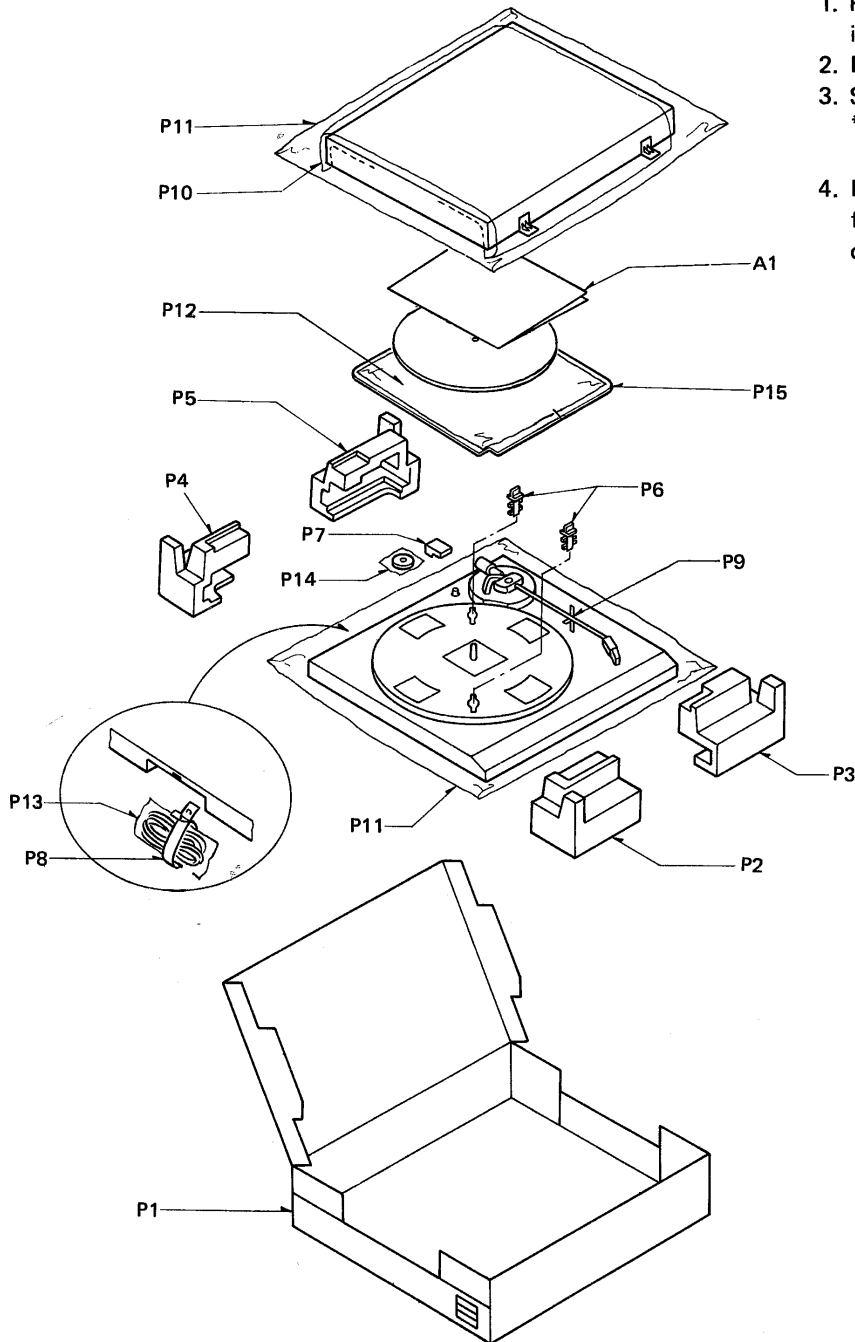

1. Place the unit (with cushions attached) as illustrated.
2. Fold the flaps according to the line marks.
3. Seal the top with adhesive tape.  
\* Use gum tape or adhesive cloth tape of 50mm wide at least.
4. For the edges, first fold the flap "a" and then flap "b", and staple. Remember to staple only flap "b". (Use 15 or 16mm staple)

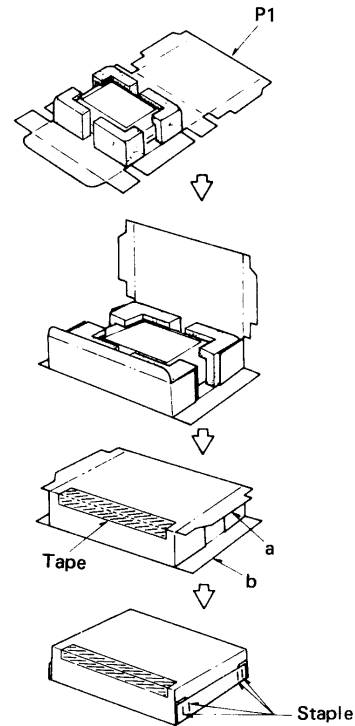

\* Stapling positions are shown below.

